



Model Name **DX832UST Digital Projector**

Unique selling point

- * 0.47 Ultra Short Throw Ratio
- * SmartEco Power Saving Technology
- * Designed for Education & IWB
- * ID Auto Keystone
- * Enhanced Dust-proof Protection



Projection System	DLP		
Native Resolution	XGA(1024 x 768)		
Brightness	3200AL		
Contrast Ratio	13000:1		
Display Color	1.07 Billion Colors		
Lens	F=2.53, f=5.38		
Aspect Ratio	Native 4:3 (5 aspect ratio selectable)		
Throw Ratio	0.47 (80" @ 0.76m)		
Image Size (Diagonal)	60"-120"		
Zoom Ratio	Fix		
Lamp Type	240W		
Lamp(Normal/Economic/SmartEco Mode/LampSave)	3000/4000/6000/7500 hours		
Keystone Adjustment	Vertical ID Auto, +/- 15 degrees		
Projection Offset	125% ±2.5%		
Resolution Support	VGA(640 x 480) to UXGA(1620 x 1200)		
Horizontal Frequency	15k-102KHz		
Vertical Scan Rate	23-120Hz		
Dust Proof	Enhanced dust-proof filter		
Interface	Computer in (D-sub 15pin)	x 1 (Share with component)	
	Monitor out (D-sub 15pin)	x 1	
	HDMI	x 2	
	Audio in (Mini Jack)	x 2	
	Audio out (Mini Jack)	x 1	
	Speaker	2W x 1	
	LAN (RJ45)	x 1	
	USB (Type A)	x1 (5V/1.5A power)	
	USB (Type MINI-B)	x1 (Download)	
	RS232 (DB-9pin)	x 1	
	IR Receiver	x2 (Front+Top)	
Dimensions	Dimensions(W x H x D)	352.9x129.4x245.4 mm	
	Weight	3.4KG	
Power	Power Supply	AC100 to 240 V, 50 to 60 Hz	
	Power Consumption	320W(typical), Standby<0.5W	
Audible Noise	35/32 dBA (Normal/Economic mode)		
On-Screen Display Languages	Arabic/Bulgarian/ Croatian/ Czech/ Danish/ Dutch/ English/ Finnish/ French/ German/ Greek/ Hindi/ Hungarian/ Italian/ Indonesian/ Japanese/ Korean/ Norwegian/ Polish/ Portuguese/ Romanian/ Russian/ Simplified Chinese/Spanish/ Swedish/ Turkish/ Thai/ Traditional Chinese (28 Languages)		
Picture Modes	Bright/ Presentation /sRGB/Cinema/User 1/User 2		
Accessories	Standard	Optional	
	Remote Control w/ Battery	Spare Lamp Kit	SJJY05.001
	Power Cord (by region)	3D Glasses	SJJ0T14.011
	User Manual CD	Wall Mount	WM6G3
	Quick Start Guide		
	Warranty Card (by region)		
	VGA(D-sub 15pin) Cable		

Environmental Notice
Lamp in this product contains mercury.
To dispose of the product or used lamps, consult your local environment authorities for regulations or see www.lamprecycle.org.

*Lamp life results will vary depending on environmental conditions and usage. Actual product's features and specifications are subject to change without notice.

** Default mode is **Presentation**. When 3D is on, Picture Modes only shows 3D. When 3D is off, it is not shown in Picture Modes.

DX832UST Digital Projector

Distance Chart

(a) Screen size				(b) Distance from screen (mm)	(c) Vertical offset (mm)
Diagonal		Height (mm)	Width (mm)		
Inches	mm				
60	1524	914	1219	573	229
70	1778	1067	1422	669	267
80	2032	1219	1626	764	305
90	2286	1372	1829	860	343
100	2540	1524	2032	955	381
110	2794	1676	2235	1051	419
120	3048	1829	2438	1146	457

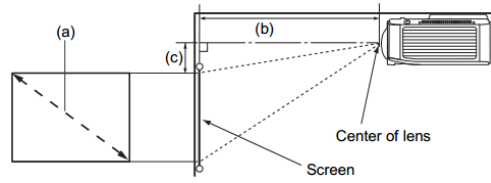

Wall mount/Ceiling mount Chart

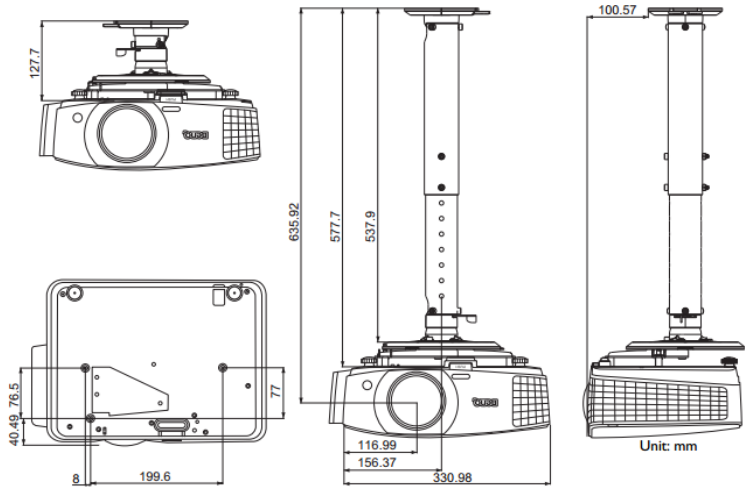

Dimension

